

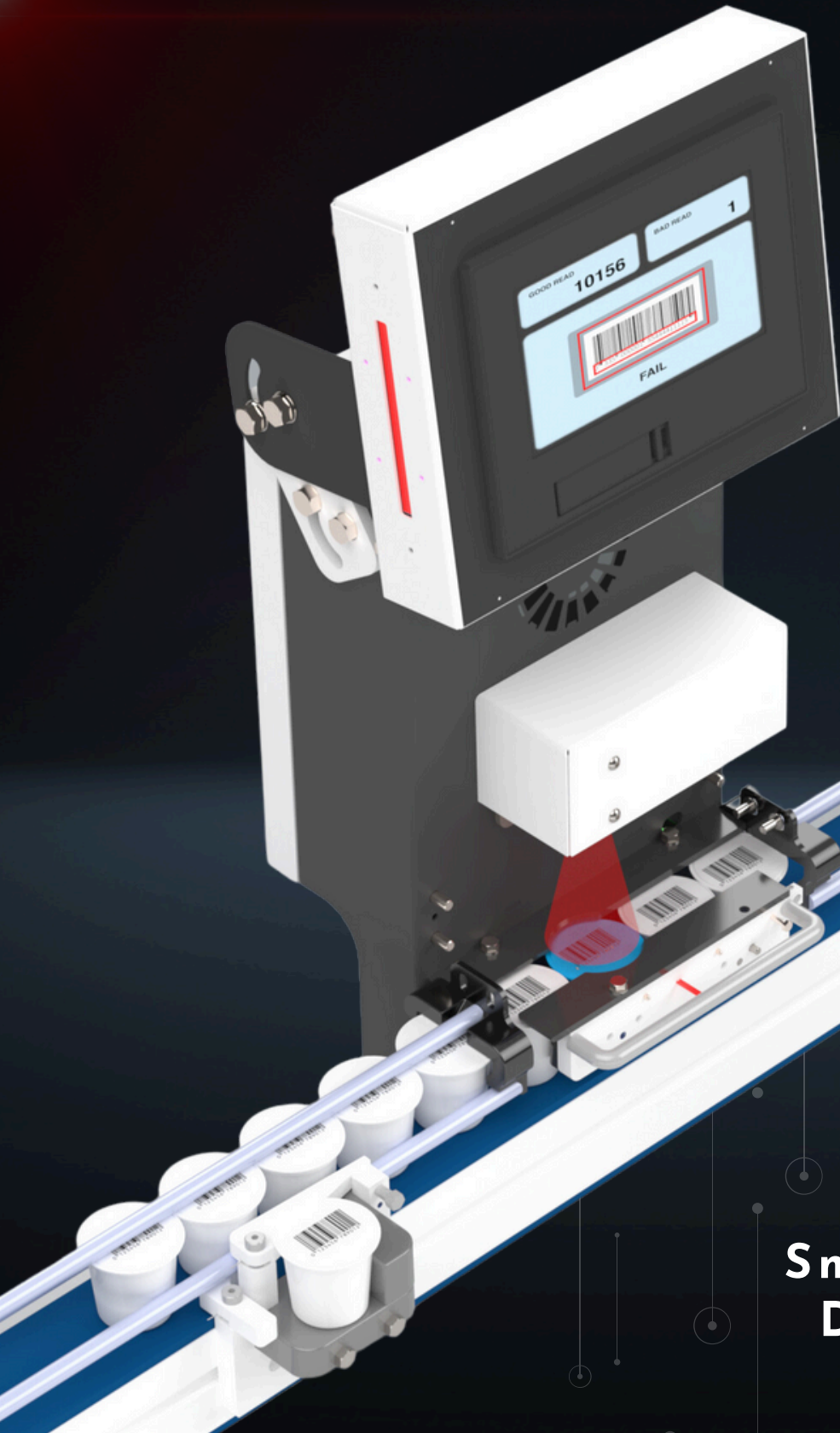

# IRIS

FACTORY AUTOMATION

## BARCODE SCANNING SYSTEM The Guardian



Bottles

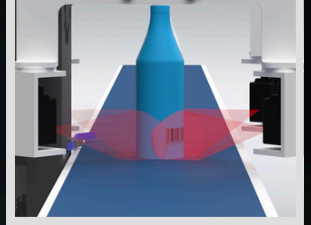

Pods



Cartons



Cups

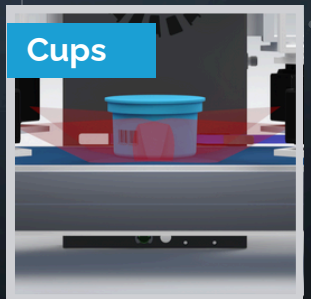

Small. Flexible.  
Data Driven.

# High-Speed Barcode Reading

*Designed to protect against brand integrity threats.*

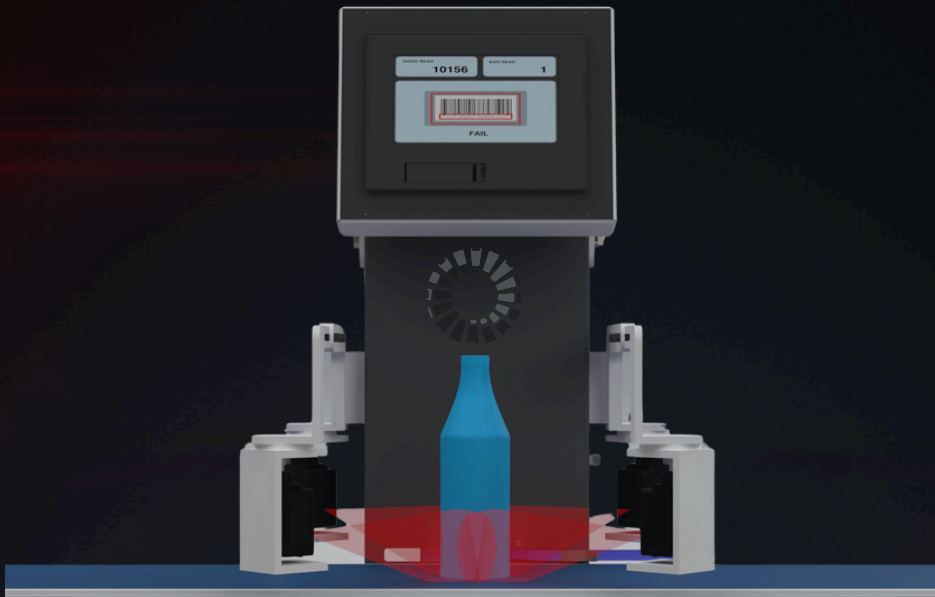

## **-Flexible barcode scanning system**

The Guardian is a high-speed barcode scanning system built to detect improperly labeled products at critical points in the workflow. Inspect barcodes using a data-driven HMI and stop non-conformities guaranteeing no bad product ever leaves your facility.

## **-Custom approach**

IRIS Factory Automation takes a consultative approach, often solving customer problems by creating products tailored to their specific needs.

# Scan. Qualify. Protect.

Ensuring Quality and Compliance  
with The Guardian Barcode Scanning System



## Scan.

Identify problems  
before they occur



## Qualify.

Immediately stop and reject  
non-conforming products



## Protect.

Protect against brand  
integrity threats

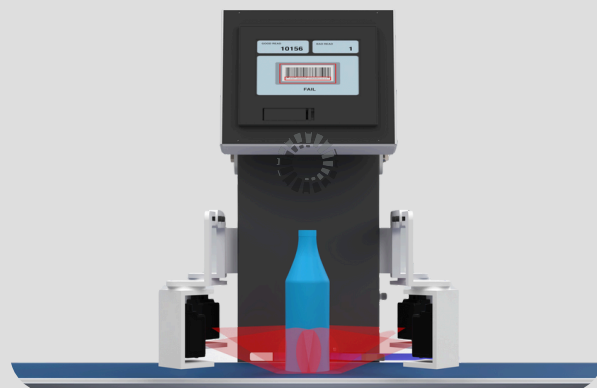



## Extremely Compact.

Designed to seamlessly integrate into any manufacturing line, the Guardian system is compact enough to fit at any point in your process, with dimensions of just 25.5 inches high, 8.5 inches deep, and 10.25 inches wide.

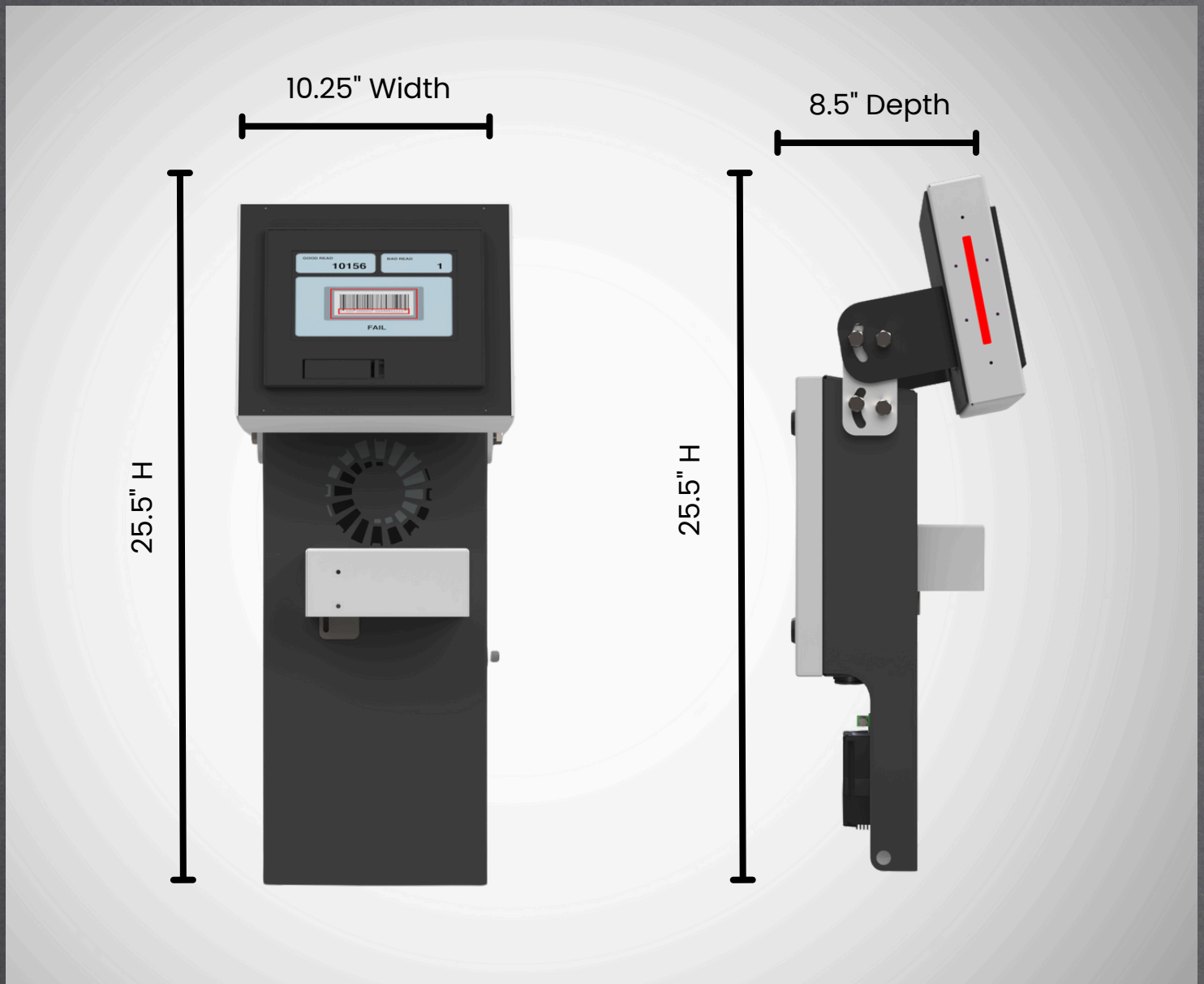

# Optimized Flexibility

Flexible HMIs, Limitless Product Orientation, and Versatile Mounting Solutions

## Mounting Flexibility

- The Guardian system can quickly mount to a T-Slot conveyor.

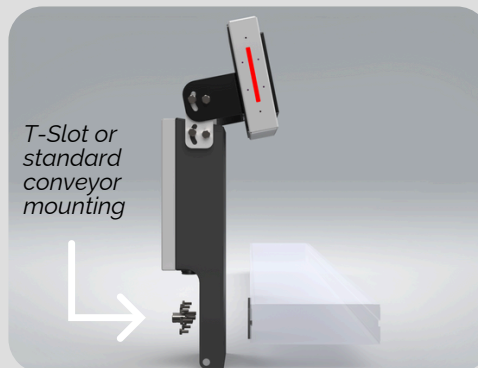

## Flexible HMI Positioning

- The 8" adjustable swivel HMI is designed for easy operational visibility and flexible mounting positions.

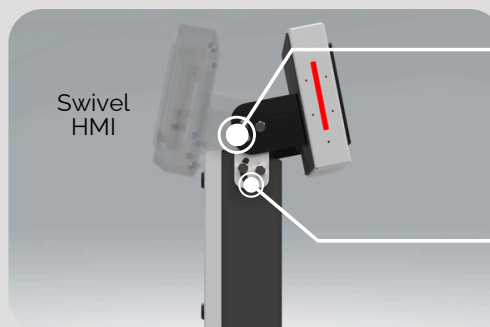

*Adjustable tilt*



*2 axis bracket*

## Defect Response

- The Guardian system can be outfitted with either a product brake or integrated rejector.



*Air reject*



*Electric reject*

## Bi-directional Product Flow

- The Guardian can accommodate bi-directional product flow, ensuring seamless and efficient operation regardless of product direction.

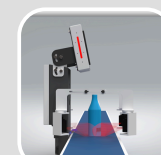
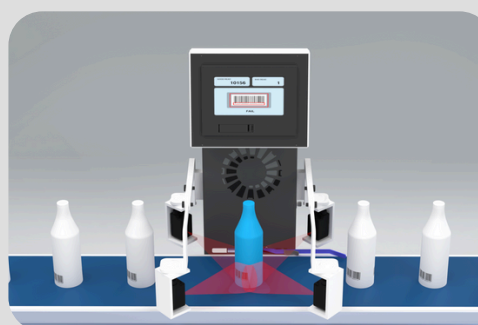

*Left infeed*



*Right infeed*

# Flexible and Configurable Scanning Coverage for a variety of product formats.

Whether dealing with cans, bottles, cups, cartons, or pouches, our system effortlessly adapts to a wide range of packaging types and sizes, ensuring consistent and accurate scanning.

## Camera Configurations

The Guardian supports limitless product orientation options thanks to its flexible camera brackets and versatile camera configurations.

### One Reader Configuration

- Top-down camera scanning configuration, ideal for scanning the top of packages.

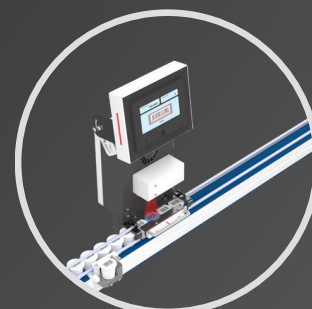
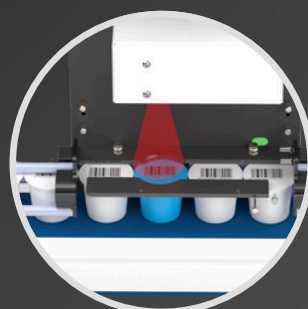
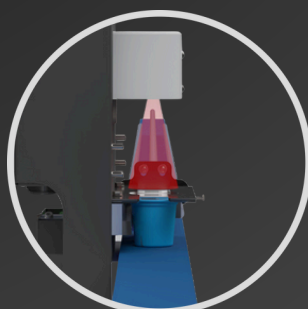

### Two Reader Configuration

- Side scanning for repeatably located barcodes on the sides of packages.

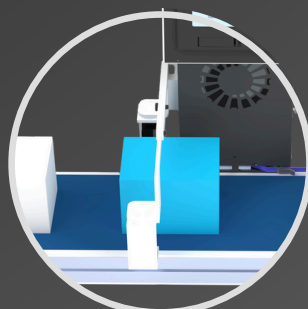
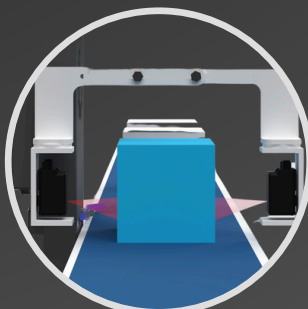

### Four Reader Configuration

- Four-reader side camera scanning configurations, ideal for round products with unknown code orientation.

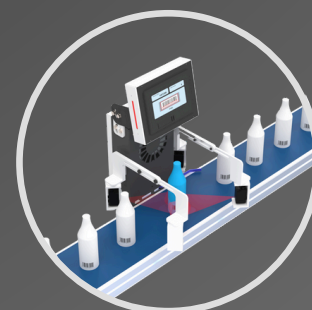
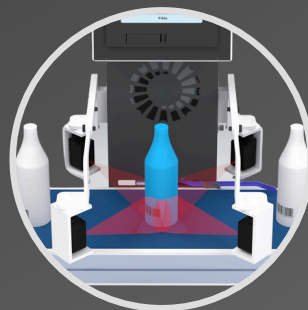
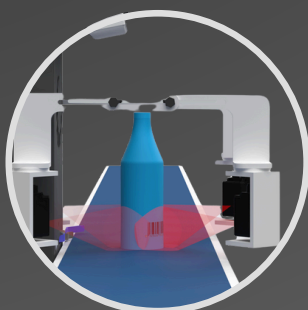

# Key Features



Flexible  
Connection



Easy  
Mounting



Lighting  
Indication



Data-Driven  
HMI



Adjustable  
Camera Brackets

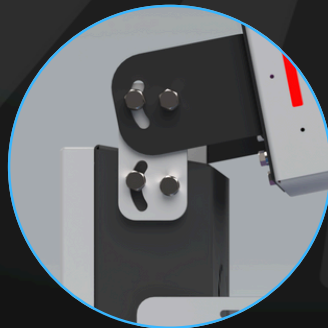

Swivel Screen



Air or Electric Reject  
Mechanisms

# Explore the Full Spectrum of Solutions with IRIS

At IRIS, we provide cutting-edge collaborative and industrial palletizing solutions that streamline operations and enhance safety, alongside small form factor case packing systems designed for precise and efficient handling of diverse products. AI-driven and traditional vision inspection technology ensures impeccable quality control, identifying defects with unmatched accuracy. Complementing these, our state-of-the-art barcode scanning system offers reliable and rapid data capture, integrating seamlessly into broader automation frameworks for comprehensive operational optimization.



**Palletizing**

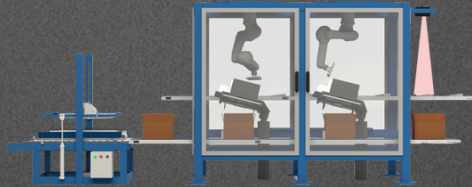

**Case Packing**

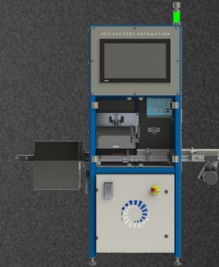

**AI & Traditional  
Vision Inspection**

## Contact Us

 Phone: (630) 634-7700

 Email: [info@iriscs.com](mailto:info@iriscs.com)

 Website: [www.irisfactoryautomation.com](http://www.irisfactoryautomation.com)